

Technical Data Sheet

Compressor model **NLY12NRb**
 Voltage **115-127V 60Hz ~1**
 Refrigerant **R290**

APPLICATION

COMPRESSOR

MOTOR

Application	Low-Medium Back Pressure	Displacement	10,70 cm ³	Nominal Power	1/3 hp
Refrigerant	R290	Diameter	25,40 mm	Voltage/Frequency	115-127V 60Hz
Evaporating Temp.	-40,0 °C to 0,0 °C	Stroke	21,12 mm	Voltage range	98-140 V
Expansion	Capillar/Valve	Net Weight	11,04 Kg	Type	CSR
Comp. Cooling	Fan cooled	Oil type	ISO VG 32 ESTER	Phase number	1 PH
Max. ambient temp.	43,0 °C	Oil charge	400 cm ³	Locked Rotor Amps (LRA)	42,00 A
				Max. Cont. Current (MCC)	8,60 A
				Main W. resist. at 25°C	1,00 Ω
				Start W. resist. at 25°C	6,50 Ω

NOMINAL PERFORMANCE

	ASHRAE	CECOMAF
Cooling Capacity	512 kCal/h	443 W
COP	1,49 W/W	1,16 W/W
EER	1,28 kCal/Wh	1,00 kCal/Wh
Input Power	399 W	383 W
Current	4,36 A	4,24 A

APPROVALS



TEST CYCLE CONDITIONS

	ASHRAE LMBP (B)	CECOMAF LMBP (A)
Evaporating temp. (T _e)	-23,3 °C	-25,0 °C
Condensing temp. (T _c)	55,0 °C	55,0 °C
Liquid temp. (T _{liq.})	32,0 °C	55,0 °C
Ambient temp. (T _{amb.})	32,0 °C	32,0 °C
Suction temp. (T _{suction})	32,0 °C	32,0 °C
Voltage/Frequency	115 V 60 Hz	115 V 60 Hz

ELECTRICAL COMPONENTS

Starting capacitor	250 µF 160 V			
Run capacitor	15 µF 250 V			
Relay	Option 1			
Reference	2014 187. + NTC3Ω			
Pick-Up	20.30 A			
Drop-Out	17.25 A			
Protector	Option 1			
Reference	T0258			
Current	23,50 A			
Time check	7,5-14 seg			
Disc temp. (Open/Close)	120,00 / 52,00 °C			

This product is approved for R290 and R600a regarding explosion safety according to standard EN 60335-1 and EN 60335-2-34

ASHRAE

Tc °C	Te °C	Cooling Capacity kCal/h	Consumption W	Current A	COP W/W	EER kCal/Wh
40	-40	214	242	3,28	1,03	0,88
40	-35	293	279	3,53	1,22	1,05
40	-30	391	319	3,79	1,43	1,23
40	-25	507	360	4,08	1,64	1,41
40	-23,3	551	375	4,18	1,71	1,47
40	-20	641	403	4,39	1,85	1,59
40	-15	793	448	4,72	2,06	1,77
40	-10	963	495	5,08	2,26	1,94
40	-5	1.151	544	5,47	2,46	2,11
40	0	1.357	595	5,88	2,65	2,28

45	-40	210	244	3,30	1,00	0,86
45	-35	287	283	3,56	1,18	1,01
45	-30	382	325	3,83	1,37	1,18
45	-25	495	368	4,14	1,57	1,35
45	-23,3	538	383	4,24	1,63	1,41
45	-20	626	413	4,46	1,77	1,52
45	-15	775	459	4,81	1,96	1,69
45	-10	943	508	5,18	2,16	1,86
45	-5	1.128	559	5,58	2,35	2,02
45	0	1.331	611	6,01	2,53	2,18

50	-40	207	247	3,31	0,97	0,84
50	-35	281	288	3,58	1,14	0,98
50	-30	373	330	3,88	1,31	1,13
50	-25	483	375	4,19	1,50	1,29
50	-23,3	525	391	4,30	1,56	1,34
50	-20	612	422	4,53	1,69	1,45
50	-15	758	470	4,89	1,87	1,61
50	-10	922	521	5,28	2,06	1,77
50	-5	1.105	573	5,70	2,24	1,93
50	0	1.305	627	6,14	2,42	2,08

55	-40	203	249	3,33	0,95	0,82
55	-35	274	292	3,61	1,09	0,94
55	-30	364	336	3,92	1,26	1,08
55	-25	471	383	4,24	1,43	1,23
55	-23,3	512	399	4,36	1,49	1,28
55	-20	597	431	4,60	1,61	1,38
55	-15	740	481	4,97	1,79	1,54
55	-10	902	533	5,38	1,97	1,69
55	-5	1.081	587	5,81	2,14	1,84
55	0	1.279	643	6,28	2,31	1,99

60	-40	200	252	3,35	0,92	0,79
60	-35	268	296	3,64	1,05	0,91
60	-30	355	342	3,96	1,21	1,04
60	-25	459	390	4,30	1,37	1,18
60	-23,3	499	407	4,42	1,43	1,23
60	-20	582	440	4,66	1,54	1,32
60	-15	723	492	5,06	1,71	1,47
60	-10	882	546	5,48	1,88	1,61
60	-5	1.058	602	5,93	2,05	1,76
60	0	1.253	659	6,42	2,21	1,90

CECOMAF

Tc °C	Te °C	Cooling Capacity W	Consumption W	Current A	COP W/W	EER kCal/Wh
40	-40	232	242	3,28	0,96	0,83
40	-35	329	279	3,53	1,18	1,02
40	-30	443	319	3,79	1,39	1,20
40	-25	573	360	4,08	1,59	1,37
40	-23,3	621	375	4,18	1,66	1,43
40	-20	720	403	4,39	1,78	1,54
40	-15	883	448	4,72	1,97	1,70
40	-10	1.063	495	5,08	2,15	1,85
40	-5	1.260	544	5,47	2,31	2,00
40	0	1.473	595	5,88	2,48	2,14

45	-40	219	244	3,30	0,90	0,77
45	-35	306	283	3,56	1,08	0,93
45	-30	409	325	3,83	1,26	1,09
45	-25	530	368	4,14	1,44	1,24
45	-23,3	574	383	4,24	1,50	1,30
45	-20	667	413	4,46	1,62	1,40
45	-15	820	459	4,81	1,79	1,54
45	-10	990	508	5,18	1,95	1,68
45	-5	1.177	559	5,58	2,11	1,82
45	0	1.381	611	6,01	2,26	1,95

50	-40	205	247	3,31	0,83	0,72
50	-35	282	288	3,58	0,98	0,85
50	-30	376	330	3,88	1,14	0,98
50	-25	487	375	4,19	1,30	1,12
50	-23,3	528	391	4,30	1,35	1,17
50	-20	614	422	4,53	1,45	1,26
50	-15	757	470	4,89	1,61	1,39
50	-10	918	521	5,28	1,76	1,52
50	-5	1.095	573	5,70	1,91	1,65
50	0	1.289	627	6,14	2,06	1,78

55	-40	191	249	3,33	0,77	0,66
55	-35	259	292	3,61	0,89	0,77
55	-30	343	336	3,92	1,02	0,88
55	-25	443	383	4,24	1,16	1,00
55	-23,3	481	399	4,36	1,21	1,04
55	-20	561	431	4,60	1,30	1,12
55	-15	695	481	4,97	1,44	1,25
55	-10	845	533	5,38	1,58	1,37
55	-5	1.012	587	5,81	1,72	1,49
55	0	1.196	643	6,28	1,86	1,61

60	-40	178	252	3,35	0,71	0,61
60	-35	235	296	3,64	0,79	0,69
60	-30	309	342	3,96	0,90	0,78
60	-25	400	390	4,30	1,03	0,89
60	-23,3	435	407	4,42	1,07	0,92
60	-20	508	440	4,66	1,15	1,00
60	-15	632	492	5,06	1,28	1,11
60	-10	773	546	5,48	1,42	1,22
60	-5	930	602	5,93	1,55	1,34
60	0	1.104	659	6,42	1,68	1,45

EN12900

X	Cooling Capacity (W)	Consumption (W)	Current (A)	Mass Flow (kg/h)
1	2,211,4074947991	479,5114620731	4,8920859706	19,902507381862
2	59,7840372907	7,9415455506	0,0650320551	0,62009612203302
3	-19,0538055515	3,2857316459	0,0279075434	-0,066357800739267
4	0,3250866098	0,0402815029	0,0005572826	0,0049080071684056
5	-0,4060536112	0,0693724083	0,0006146832	-0,0014442071898408

Equation	$x_1 + x_2Te + x_3Tc + x_4Te^2 + x_5TeTc$
----------	---

Technical Data Sheet

COMPRESSOR DIMENSIONS

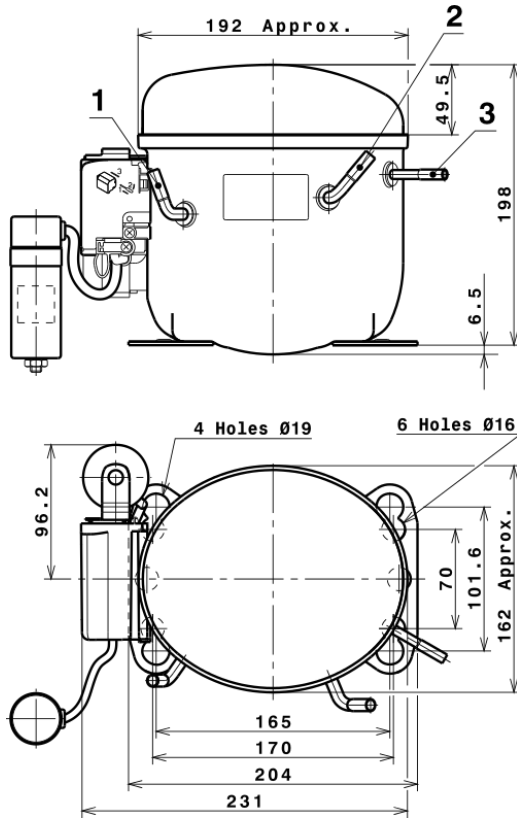

DESIGNATION INTERNAL DIAM.

1	Suction	8,1 mm
2	Service	8,1 mm
3	Discharge	6,5 mm

WIRING DIAGRAMS AND ELECTRICAL ASSEMBLY

CSR CONNECTION (CURRENT RELAY + NTC) (L, P ranges)

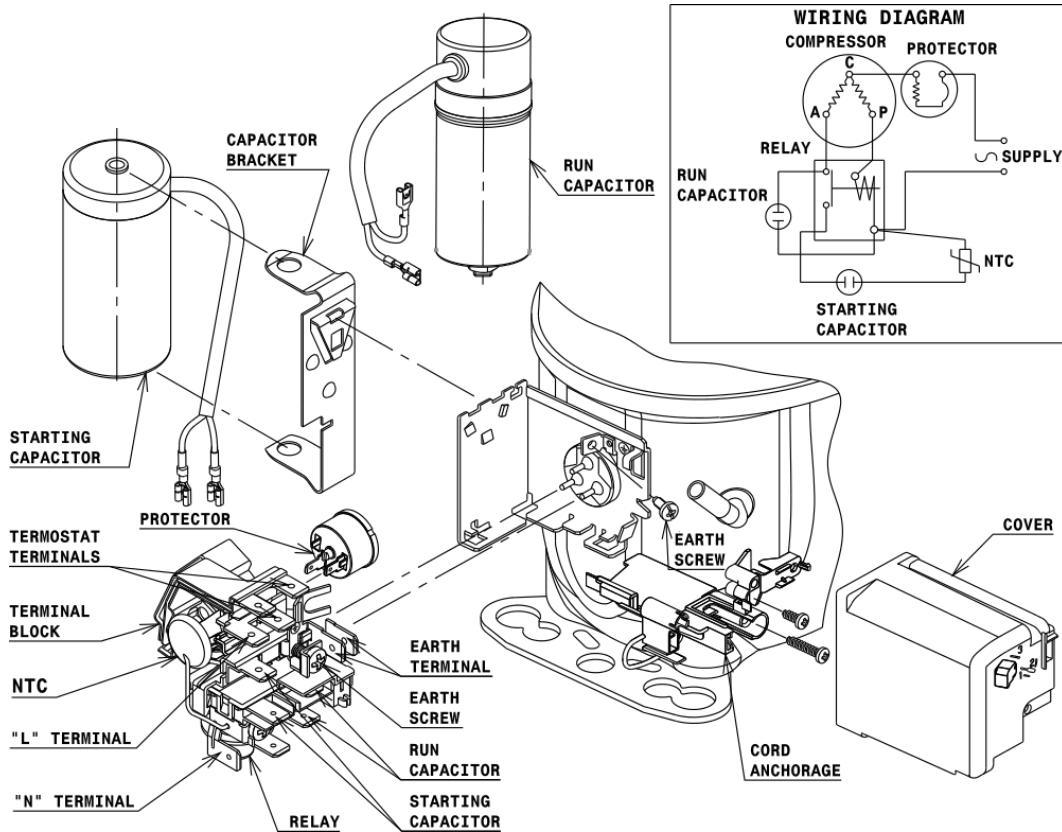

Technical Data Sheet

FIXINGS



SILENT BLOCKS (MOUNTING ACCESSORIES)

STANDARD

Ø16 holes (170x70 net)



AMERICAN FEET

Ø19 holes (165x101.6 net)



SNAP-ON

Ø16 holes (170x70 net)



SOA

SOA R290 LMBP

