

NLE8.8CN Energy-optimized LBP/MBP Compressor R290 220-240V 50Hz

General

Code number	105H6880
Approvals	EN 60335-2-34 w. Annex AA
Compressors on pallet	80

Application

Application	LBP/MBP		
	Hz	50	60
Frequency	Hz	50	60
Evaporating temperature	°C	-35 to 10	-
Voltage range	V	198 to 254	-
Max. condensing temperature continuous (short)	°C	65 (65)	-
Max. winding temperature continuous (short)	°C	125 (135)	-

Cooling requirements

Frequency	Hz	50			60		
		LBP	MBP	HBP	LBP	MBP	HBP
32°C		F ₂	F ₂	-	-	-	-
38°C		F ₂	F ₂	-	-	-	-
43°C		F ₂	F ₂	-	-	-	-
Remarks on application:							

Motor

Motor type	CSIR/RSIR/RSCR		
LRA (rated after 4 sec. UL984), HST LST	A	11.3	10.7
Cut in Current, HST LST	A	11.3	15.9
Resistance, main start winding (25°C)	Ω	9.0	12.0

Design

Displacement	cm ³	8.76
Oil quantity (type)	cm ³	300 (polyolester)
Maximum refrigerant charge	g	150
Free gas volume in compressor	cm ³	2360
Weight without electrical equipment	kg	12.1

Dimensions

Height	mm	A	203
		B	197
		B1	-
		B2	-
Suction connector	location/I.D. mm angle	C	8.2 15°
		material comment	Copper Rubber plug
Process connector	location/I.D. mm angle	D	6.2 25°
		material comment	Copper Rubber plug
Discharge connector	location/I.D. mm angle	E	6.2 21°
		material comment	Copper Rubber plug
Oil cooler connector	location/I.D. mm angle	F	-
		material comment	-
Connector tolerance	I.D. mm		±0.09
Remarks:			

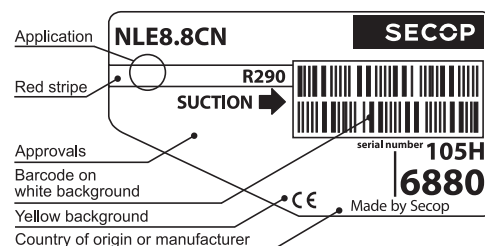

- S = Static cooling normally sufficient
- O = Oil cooling
- F₁ = Fan cooling 1.5 m/s (compressor compartment temperature equal to ambient temperature)
- F₂ = Fan cooling 3.0 m/s necessary
- SG = Suction gas cooling normally sufficient
- = not applicable in this area

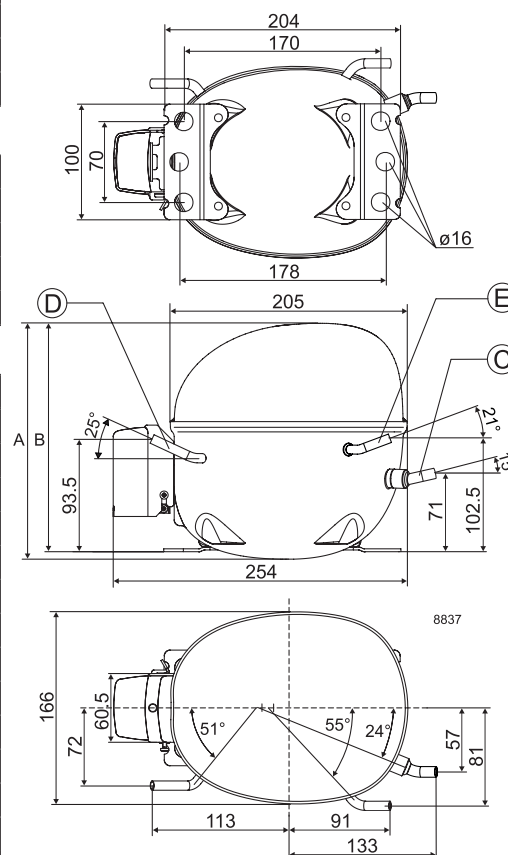

EN 12900 LBP

220V, 50Hz, fan cooling F₂

Evap. temp. in °C	-45	-40	-35	-30	-25	-23.3	-20	-15	-10	-6.7	-5	0	5	7.2	10	15	20
Capacity in W			259	321	397	426	487	596	723	819	873	1046	1244	1341	1472		
Power cons. in W			212	234	257	265	280	302	323	336	342	358	371	375	379		
Current cons. in A			1.55	1.61	1.67	1.69	1.74	1.81	1.88	1.92	1.94	2.00	2.04	2.05	2.07		
COP in W/W			1.22	1.37	1.54	1.61	1.74	1.97	2.24	2.44	2.55	2.92	3.36	3.58	3.88		

EN 12900 MBP

220V, 50Hz, fan cooling F₂

Evap. temp. in °C	-45	-40	-35	-30	-25	-23.3	-20	-15	-10	-6.7	-5	0	5	7.2	10	15	20
Capacity in W			242	304	376	404	462	564	683	772	821	981	1165	1254	1375		
Power cons. in W			216	241	267	275	293	318	343	358	366	386	404	411	418		
Current cons. in A			1.56	1.63	1.70	1.73	1.78	1.86	1.95	2.00	2.03	2.10	2.16	2.19	2.21		
COP in W/W			1.12	1.26	1.41	1.47	1.58	1.77	1.99	2.15	2.24	2.54	2.88	3.05	3.29		

ASHRAE LBP

220V, 50Hz, fan cooling F₂

Evap. temp. in °C	-45	-40	-35	-30	-25	-23.3	-20	-15	-10	-6.7	-5	0	5	7.2	10	15	20
Capacity in W			236	312	398	430	497	611	742	839	893	1067	1267	1364	1496		
Power cons. in W			202	232	264	275	296	328	360	380	390	418	444	454	466		
Current cons. in A			1.54	1.63	1.73	1.76	1.84	1.95	2.07	2.15	2.19	2.30	2.41	2.46	2.51		
COP in W/W			1.17	1.34	1.51	1.57	1.68	1.86	2.06	2.21	2.29	2.55	2.85	3.00	3.21		

ASHRAE MBP/HBP

220V, 50Hz, fan cooling F₂

Evap. temp. in °C	-45	-40	-35	-30	-25	-23.3	-20	-15	-10	-6.7	-5	0	5	7.2	10	15	20
Capacity in W			211	279	356	385	444	545	662	748	796	950	1127	1212	1328		
Power cons. in W			200	230	261	272	293	325	356	376	386	413	439	449	460		
Current cons. in A			1.54	1.63	1.73	1.76	1.84	1.95	2.07	2.15	2.19	2.30	2.41	2.46	2.51		
COP in W/W			1.06	1.21	1.36	1.41	1.51	1.68	1.86	1.99	2.06	2.30	2.57	2.70	2.89		

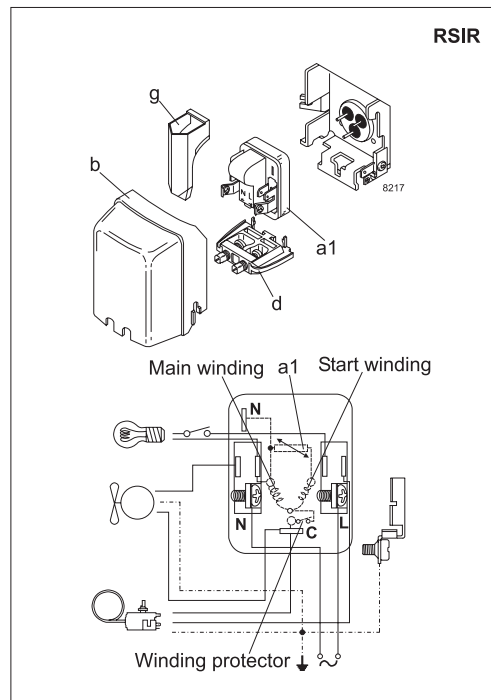
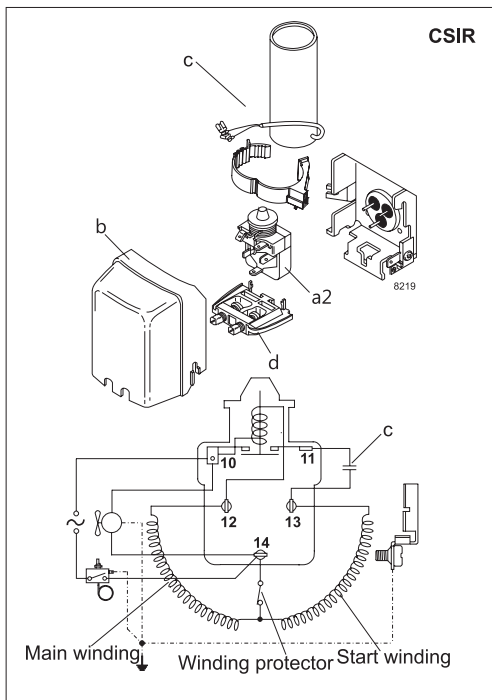

Accessories for	NLE8.8CN	Figure	Code number
ePTC starting device	6.3 mm spade connectors	a1	-
	4.8 mm spade connectors		103N0050
Starting relay	6.3 mm spade connectors	a2	117U7002
Start. capacitor 80 µF	6.3 mm spade connectors	c	117U5015
Cover		b	103N2010
Cord relief		d	103N1010
Protection screen for PTC		g	-

Test conditions	EN 12900		ASHRAE	
	LBP	MBP	LBP	MBP
Condensing temperature	40°C	45°C	54.4°C	54.4°C
Ambient temperature	32°C	32°C	32.2°C	35°C
Suction gas temperature	20°C	20°C	32.2°C	35°C
Liquid temperature	no subcooling		32.2°C	46.1°C

Mounting accessories	Code number	
Bolt joint for one comp.	Ø: 16 mm	118-1917
Bolt joint in quantities	Ø: 16 mm	118-1918
Snap-on in quantities	Ø: 16 mm	118-1919

EN 12900 LBP

220V, 50Hz, RC 4 µF, ePTC consumption incl., fan cooling F₂

Evap. temp. in °C	-45	-40	-35	-30	-25	-23.3	-20	-15	-10	-6.7	-5	0	5	7.2	10	15	20
Capacity in W			261	324	401	430	492	602	731	827	881	1056	1257	1354	1486		
Power cons. in W			205	226	248	255	269	291	311	323	329	344	356	360	364		
Current cons. in A			1.30	1.32	1.37	1.39	1.43	1.50	1.58	1.63	1.65	1.72	1.77	1.79	1.80		
COP in W/W			1.28	1.44	1.62	1.69	1.83	2.07	2.35	2.56	2.68	3.07	3.53	3.76	4.08		

EN 12900 MBP

220V, 50Hz, RC 4 µF, ePTC consumption incl., fan cooling F₂

Evap. temp. in °C	-45	-40	-35	-30	-25	-23.3	-20	-15	-10	-6.7	-5	0	5	7.2	10	15	20
Capacity in W			245	307	380	408	467	569	689	779	829	991	1177	1267	1389		
Power cons. in W			208	232	257	265	282	307	331	346	353	373	390	396	403		
Current cons. in A			1.31	1.36	1.42	1.45	1.51	1.60	1.70	1.77	1.80	1.89	1.97	2.00	2.02		
COP in W/W			1.18	1.32	1.48	1.54	1.66	1.85	2.08	2.25	2.35	2.66	3.02	3.20	3.44		

ASHRAE LBP

220V, 50Hz, RC 4 µF, ePTC consumption incl., fan cooling F₂

Evap. temp. in °C	-45	-40	-35	-30	-25	-23.3	-20	-15	-10	-6.7	-5	0	5	7.2	10	15	20
Capacity in W			238	315	402	435	502	617	749	848	902	1078	1280	1378	1511		
Power cons. in W			194	223	253	264	284	315	346	365	375	401	426	435	446		
Current cons. in A			1.26	1.33	1.43	1.46	1.54	1.67	1.80	1.89	1.93	2.06	2.17	2.22	2.27		
COP in W/W			1.23	1.41	1.59	1.65	1.77	1.96	2.17	2.32	2.41	2.69	3.01	3.17	3.38		

ASHRAE MBP/HBP

220V, 50Hz, RC 4 µF, ePTC consumption incl., fan cooling F₂

Evap. temp. in °C	-45	-40	-35	-30	-25	-23.3	-20	-15	-10	-6.7	-5	0	5	7.2	10	15	20
Capacity in W			213	282	360	388	448	550	668	756	804	960	1138	1225	1342		
Power cons. in W			192	221	251	261	281	312	342	361	370	397	420	430	441		
Current cons. in A			1.26	1.33	1.43	1.46	1.54	1.67	1.80	1.89	1.93	2.06	2.17	2.22	2.27		
COP in W/W			1.11	1.28	1.43	1.49	1.59	1.76	1.95	2.09	2.17	2.42	2.71	2.85	3.05		

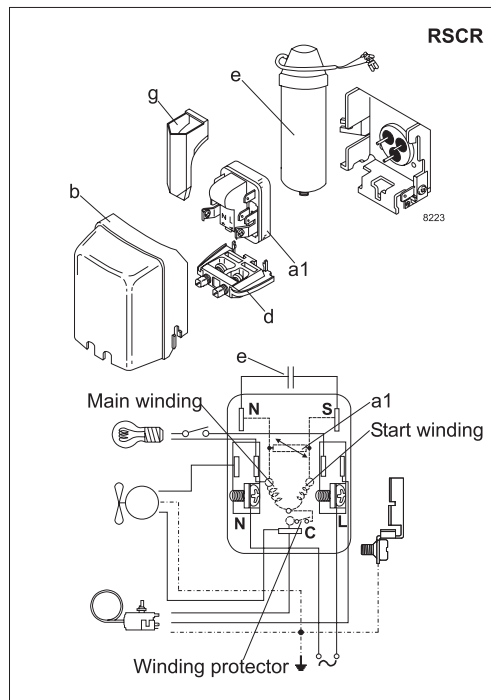

Accessories for	NLE8.8CN	Figure	Code number
ePTC starting device	6.3 mm spade connectors	a1	-
	4.8 mm spade connectors		103N0050
Run capacitor 4 µF (optional)	4.8 mm spade connectors	e	117-7119
Cover		b	103N2010
Cord relief		d	103N1010
Protection screen for PTC		g	-

Test conditions	EN 12900		ASHRAE	
	LBP	MBP	LBP	MBP
Condensing temperature	40°C	45°C	54.4°C	54.4°C
Ambient temperature	32°C	32°C	32.2°C	35°C
Suction gas temperature	20°C	20°C	32.2°C	35°C
Liquid temperature	no subcooling		32.2°C	46.1°C

Mounting accessories	Code number	
Bolt joint for one comp.	Ø: 16 mm	118-1917
Bolt joint in quantities	Ø: 16 mm	118-1918
Snap-on in quantities	Ø: 16 mm	118-1919

Nidec GA Compressors accepts no responsibility for possible errors in catalogs, brochures, and other printed material. Nidec GA Compressors reserves the right to alter its products without notice. This also applies to products already on order provided that such alterations can be made without consequential changes being necessary to specifications already agreed. All trademarks in this material are the property of the respective companies. Secop and the Secop logotype are trademarks of Nidec Global Appliance Germany GmbH. All rights reserved. www.secop.com