

Technical Data Sheet

Compressor model **HLY55AAa**
 Voltage **220-240V 50Hz ~1**
 Refrigerant **R600a**

APPLICATION

Application Low Back Pressure
 Refrigerant R600a
 Evaporating Temp. -35,0 °C to -10,0 °C
 Expansion Capillar
 Comp. Cooling Static
 Max. ambient temp. 43,0 °C

COMPRESSOR

Displacement 5,46 cm³
 Diameter 20,88 mm
 Stroke 15,93 mm
 Net Weight 9,25 Kg
 Oil type ISO VG 10 MINER
 Oil charge 210 cm³

MOTOR

Nominal Power 1/9 hp
 Voltage/Frequency 220-240V 50Hz
 Voltage range 187-264 V
 Type RSIR
 Phase number 1 PH
 Locked Rotor Amps (LRA) 6,30 A
 Max. Cont. Current (MCC) 0,80 A
 Main W. resist. at 25°C 29,57 Ω
 Start W. resist. at 25°C 32,83 Ω

NOMINAL PERFORMANCE

	ASHRAE	CECOMAF
Cooling Capacity	72 kCal/h	62 W
COP	1,33 W/W	1,03 W/W
EER	1,14 kCal/Wh	0,89 kCal/Wh
Input Power	63 W	60 W
Current	0,45 A	0,44 A

APPROVALS



TEST CYCLE CONDITIONS

	ASHRAE LBP (B)	CECOMAF LBP (A)
Evaporating temp. (T _e)	-23,3 °C	-25,0 °C
Condensing temp. (T _c)	55,0 °C	55,0 °C
Liquid temp. (T _{liq.})	32,0 °C	55,0 °C
Ambient temp. (T _{amb.})	32,0 °C	32,0 °C
Suction temp. (T _{suction})	32,0 °C	32,0 °C
Voltage/Frequency	220 V 50 Hz	220 V 50 Hz

ELECTRICAL COMPONENTS

Relay	Option 1			
Reference	PTC K100			
Voltage	200-240 V			
Resistance	14.00 Ω			
Protector	Option 1	Option 2	Option 3	Option 4
Reference	MSP505HK	4TM142NFBYY	T0492	AE23BY
Current	3,60 A	4,20 A	4,80 A	3,60 A
Time check	7,5-14 seg	5-15 seg	7,5-14 seg	7,5-14 seg
Disc temp. (Open/Close)	105,00 / 62,00 °C	120,00 / 61,00 °C	95,00 / 61,00 °C	105,00 / 62,00 °C

This product is approved for R290 and R600a regarding explosion safety according to standard EN 60335-1 and EN 60335-2-34

ASHRAE

Tc °C	Te °C	Cooling Capacity kCal/h	Consumption W	Current A	COP W/W	EER kCal/Wh
40	-35	35	48	0,41	0,85	0,73
40	-30	53	54	0,42	1,14	0,98
40	-25	73	61	0,44	1,41	1,21
40	-23,3	81	63	0,45	1,50	1,29
40	-20	96	67	0,46	1,67	1,43
40	-15	121	73	0,49	1,91	1,64
40	-10	148	80	0,51	2,15	1,85

45	-35	33	47	0,41	0,82	0,71
45	-30	51	54	0,42	1,10	0,95
45	-25	71	60	0,44	1,36	1,17
45	-23,3	78	63	0,45	1,44	1,24
45	-20	93	67	0,46	1,60	1,37
45	-15	117	75	0,49	1,83	1,57
45	-10	144	82	0,52	2,05	1,76

50	-35	31	45	0,40	0,80	0,68
50	-30	48	53	0,42	1,06	0,91
50	-25	68	60	0,44	1,31	1,12
50	-23,3	75	63	0,45	1,38	1,19
50	-20	90	68	0,47	1,53	1,32
50	-15	114	76	0,49	1,75	1,50
50	-10	140	83	0,52	1,95	1,68

55	-35	29	44	0,40	0,77	0,66
55	-30	46	52	0,42	1,02	0,88
55	-25	65	60	0,44	1,25	1,08
55	-23,3	72	63	0,45	1,33	1,14
55	-20	86	68	0,47	1,47	1,26
55	-15	110	77	0,50	1,67	1,44
55	-10	136	85	0,53	1,86	1,60

60	-35	27	43	0,40	0,74	0,63
60	-30	43	51	0,42	0,98	0,85
60	-25	62	60	0,44	1,20	1,03
60	-23,3	69	63	0,45	1,27	1,10
60	-20	83	69	0,47	1,40	1,21
60	-15	106	78	0,50	1,59	1,37
60	-10	132	87	0,54	1,77	1,52

CECOMAF

Tc °C	Te °C	Cooling Capacity W	Consumption W	Current A	COP W/W	EER kCal/Wh
40	-35	38	48	0,41	0,80	0,69
40	-30	59	54	0,42	1,08	0,93
40	-25	81	61	0,44	1,34	1,16
40	-23,3	89	63	0,45	1,42	1,23
40	-20	106	67	0,46	1,58	1,36
40	-15	133	73	0,49	1,81	1,56
40	-10	162	80	0,51	2,02	1,75

45	-35	35	47	0,41	0,75	0,64
45	-30	54	54	0,42	1,00	0,87
45	-25	75	60	0,44	1,24	1,07
45	-23,3	83	63	0,45	1,31	1,13
45	-20	98	67	0,46	1,45	1,26
45	-15	124	75	0,49	1,66	1,43
45	-10	151	82	0,52	1,85	1,60

50	-35	31	45	0,40	0,69	0,60
50	-30	49	53	0,42	0,92	0,80
50	-25	69	60	0,44	1,14	0,98
50	-23,3	76	63	0,45	1,20	1,04
50	-20	90	68	0,47	1,33	1,15
50	-15	114	76	0,49	1,51	1,31
50	-10	141	83	0,52	1,69	1,46

55	-35	28	44	0,40	0,63	0,55
55	-30	44	52	0,42	0,84	0,73
55	-25	62	60	0,44	1,03	0,89
55	-23,3	69	63	0,45	1,09	0,95
55	-20	83	68	0,47	1,21	1,04
55	-15	105	77	0,50	1,37	1,19
55	-10	130	85	0,53	1,53	1,32

60	-35	24	43	0,40	0,57	0,49
60	-30	39	51	0,42	0,76	0,66
60	-25	56	60	0,44	0,93	0,80
60	-23,3	62	63	0,45	0,99	0,85
60	-20	75	69	0,47	1,09	0,94
60	-15	96	78	0,50	1,24	1,07
60	-10	120	87	0,54	1,38	1,19

EN12900

X	Cooling Capacity (W)	Consumption (W)	Current (A)	Mass Flow (kg/h)
1	329,7658109513	71,9565849092	0,4956165424	3,2584357820498
2	9,0259193550	0,3930033429	0,0042578377	0,095959198487537
3	-2,7189119993	0,5860774924	0,0022290720	-0,012613316637531
4	0,0419846016	0,0013906396	0,0000735177	0,00062241722519197
5	-0,0577231214	0,0245249415	0,0000816715	-0,00021196032166699

Equation	$x_1 + x_2Te + x_3Tc + x_4Te^2 + x_5TeTc$
----------	---

Technical Data Sheet

COMPRESSOR DIMENSIONS

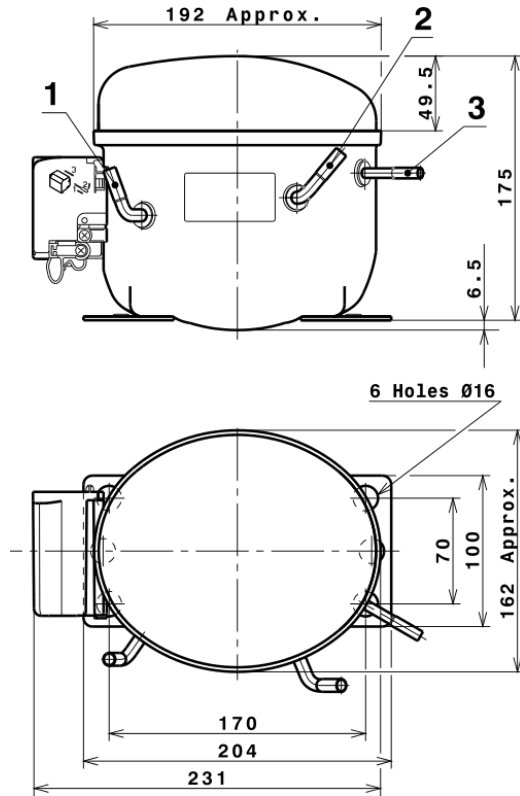

DESIGNATION INTERNAL DIAM.

DESIGNATION	INTERNAL DIAM.
1 Suction	6,5 mm
2 Service	6,5 mm
3 Discharge	4,9 mm

WIRING DIAGRAMS AND ELECTRICAL ASSEMBLY

RSIR CONNECTION (PTC) (L, P ranges)

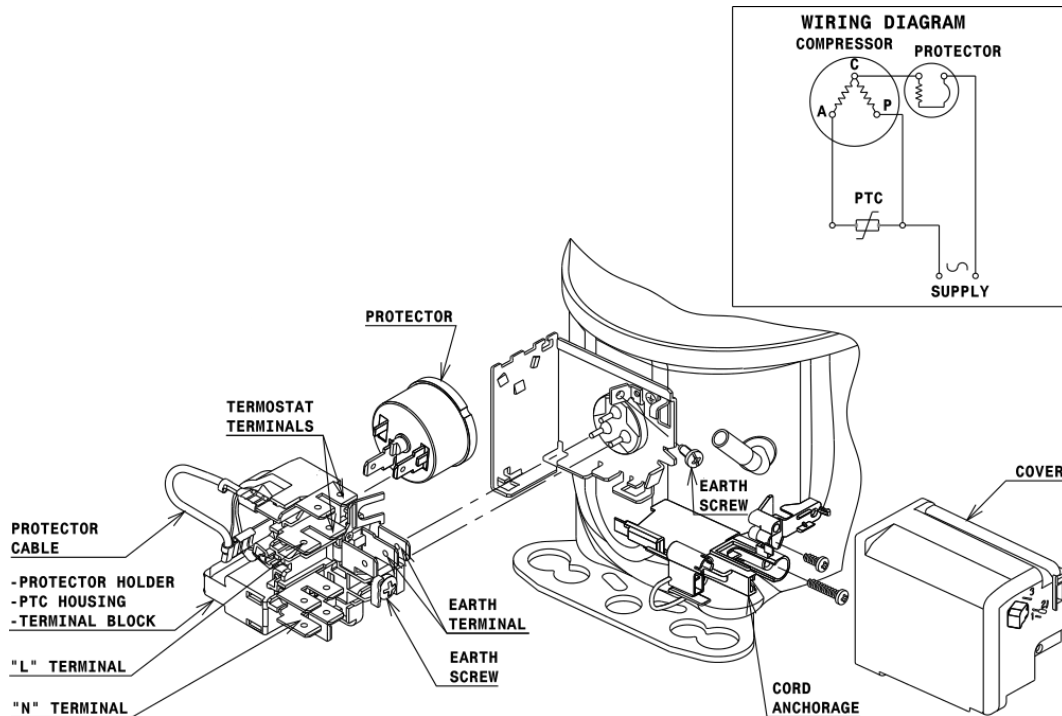

FIXINGS

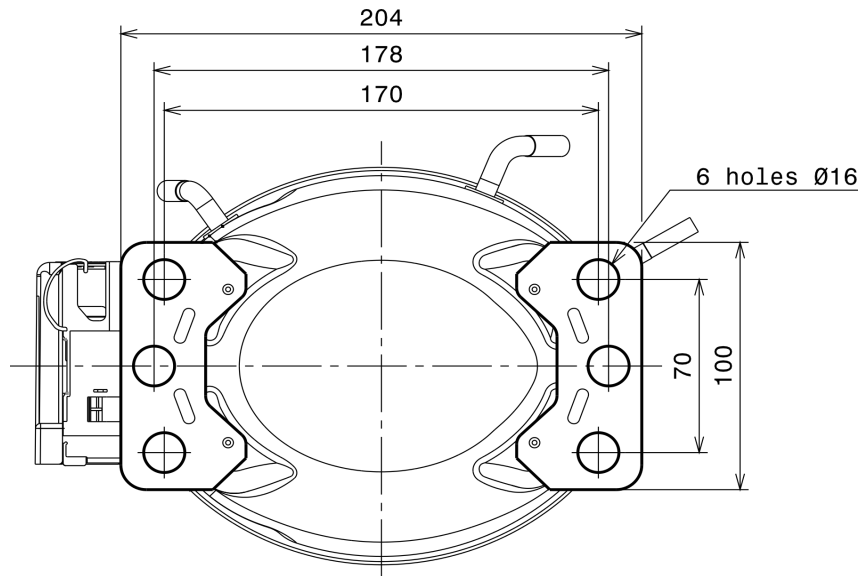

SILENT BLOCKS (MOUNTING ACCESSORIES)

STANDARD

$\varnothing 16$ holes (170x70 net)



SNAP-ON

$\varnothing 16$ holes (170x70 net)

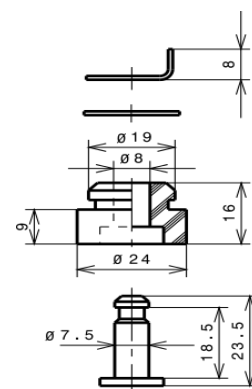

SOA

SOA R600a LBP

