

Technical Data Sheet

Compressor model **GUY90RAa**
 Voltage **220-240V 50Hz ~1**
 Refrigerant **R134a**

APPLICATION

COMPRESSOR

MOTOR

Application	High-Medium Back Pressure	Displacement	8,80 cm ³	Nominal Power	1/4 hp
Refrigerant	R134a	Diameter	24,30 mm	Voltage/Frequency	220-240V 50Hz
Evaporating Temp.	-25,0 °C to 10,0 °C	Stroke	19,00 mm	Voltage range	187-255 V
Expansion	Capillar/Valve	Net Weight	9,70 Kg	Type	CSIR
Comp. Cooling	Fan cooled	Oil type	ISO VG 32 ESTER	Phase number	1 PH
Max. ambient temp.	43,0 °C	Oil charge	200 cm ³	Locked Rotor Amps (LRA)	14,50 A
Compatible refriger.	R1234yf			Max. Cont. Current (MCC)	3,00 A
				Main W. resist. at 25°C	6,90 Ω
				Start W. resist. at 25°C	32,95 Ω

NOMINAL PERFORMANCE

APPROVALS

	ASHRAE	CECOMAF
Cooling Capacity	796 kCal/h	775 W
COP	2,56 W/W	2,21 W/W
EER	2,20 kCal/Wh	1,91 kCal/Wh
Input Power	361 W	350 W
Current	2,19 A	2,15 A

TEST CYCLE CONDITIONS

	ASHRAE HMBP (D)	CECOMAF HMBP (C)
Evaporating temp. (T _e)	7,2 °C	5,0 °C
Condensing temp. (T _c)	55,0 °C	55,0 °C
Liquid temp. (T _{liq.})	46,0 °C	55,0 °C
Ambient temp. (T _{amb.})	35,0 °C	32,0 °C
Suction temp. (T _{suction})	35,0 °C	32,0 °C
Voltage/Frequency	220 V 50 Hz	220 V 50 Hz

ELECTRICAL COMPONENTS

Starting capacitor	47- 56 µF 330 V		
Relay	Option 1		
Reference	2014 135.		
Pick-Up	5,80 A		
Drop-Out	4,95 A		
Protector	Option 1	Option 2	
Reference	T0137	AE39FHS	
Current	9,50 A	9,20 A	
Time check	7,5-14 seg	7,5-14 seg	
Disc temp. (Open/Close)	110,00 / 61,00 °C	105,00 / 62,00 °C	

ASHRAE

Tc °C	Te °C	Cooling Capacity kCal/h	Consumption W	Current A	COP W/W	EER kCal/Wh
40	-25	208	173	1,62	1,40	1,20
40	-20	283	193	1,67	1,71	1,47
40	-15	374	213	1,71	2,04	1,75
40	-10	479	234	1,77	2,38	2,05
40	-5	599	254	1,83	2,74	2,35
40	0	734	276	1,89	3,09	2,66
40	5	883	297	1,96	3,46	2,97
40	7,2	954	307	1,99	3,61	3,11
40	10	1.048	319	2,03	3,82	3,28

45	-25	196	176	1,63	1,30	1,12
45	-20	265	198	1,68	1,56	1,34
45	-15	349	220	1,73	1,84	1,58
45	-10	448	243	1,79	2,14	1,84
45	-5	562	267	1,86	2,45	2,11
45	0	690	290	1,94	2,76	2,38
45	5	834	314	2,02	3,08	2,65
45	7,2	901	325	2,05	3,23	2,77
45	10	992	339	2,10	3,41	2,93

50	-25	184	178	1,63	1,20	1,03
50	-20	247	203	1,69	1,41	1,22
50	-15	324	228	1,75	1,66	1,42
50	-10	417	253	1,82	1,92	1,65
50	-5	524	279	1,90	2,19	1,88
50	0	647	305	1,98	2,47	2,12
50	5	784	331	2,08	2,75	2,37
50	7,2	849	343	2,12	2,88	2,47
50	10	936	358	2,18	3,04	2,61

55	-25	172	181	1,64	1,11	0,95
55	-20	228	208	1,70	1,28	1,10
55	-15	300	235	1,77	1,48	1,27
55	-10	386	263	1,85	1,71	1,47
55	-5	487	291	1,94	1,95	1,67
55	0	603	319	2,03	2,20	1,89
55	5	734	348	2,14	2,45	2,11
55	7,2	796	361	2,19	2,56	2,20
55	10	879	377	2,26	2,71	2,33

60	-25	160	184	1,65	1,01	0,87
60	-20	210	213	1,71	1,15	0,99
60	-15	275	243	1,79	1,32	1,13
60	-10	355	273	1,88	1,51	1,30
60	-5	450	303	1,98	1,73	1,48
60	0	559	334	2,09	1,95	1,67
60	5	684	365	2,21	2,18	1,87
60	7,2	743	379	2,26	2,28	1,96
60	10	823	397	2,34	2,41	2,08

65	-25	148	186	1,65	0,92	0,79
65	-20	192	218	1,73	1,02	0,88
65	-15	251	250	1,81	1,16	1,00
65	-10	324	283	1,91	1,33	1,15
65	-5	413	315	2,02	1,52	1,31
65	0	516	349	2,14	1,72	1,48
65	5	634	382	2,28	1,93	1,66
65	7,2	691	397	2,34	2,02	1,74
65	10	767	416	2,42	2,14	1,84

CECOMAF

Tc °C	Te °C	Cooling Capacity W	Consumption W	Current A	COP W/W	EER kCal/Wh
40	-25	224	174	1,63	1,29	1,11
40	-20	306	194	1,67	1,58	1,36
40	-15	404	214	1,72	1,89	1,63
40	-10	517	235	1,77	2,20	1,90
40	-5	646	256	1,83	2,53	2,18
40	0	791	277	1,89	2,85	2,46
40	5	951	299	1,96	3,18	2,75
40	7,2	1.027	309	2,00	3,32	2,87
40	10	1.127	321	2,04	3,51	3,03

45	-25	210	177	1,63	1,19	1,03
45	-20	285	199	1,68	1,43	1,24
45	-15	375	222	1,74	1,69	1,46
45	-10	481	245	1,80	1,97	1,70
45	-5	602	268	1,87	2,25	1,94
45	0	740	292	1,94	2,53	2,19
45	5	892	316	2,02	2,82	2,44
45	7,2	965	327	2,06	2,95	2,55
45	10	1.061	341	2,11	3,11	2,69

50	-25	196	179	1,64	1,09	0,94
50	-20	263	204	1,69	1,29	1,11
50	-15	346	229	1,76	1,51	1,31
50	-10	445	255	1,83	1,75	1,51
50	-5	559	280	1,90	1,99	1,72
50	0	688	307	1,99	2,24	1,94
50	5	834	333	2,08	2,50	2,16
50	7,2	903	345	2,13	2,61	2,26
50	10	995	360	2,19	2,76	2,38

55	-25	182	182	1,64	1,00	0,86
55	-20	242	209	1,70	1,16	1,00
55	-15	317	237	1,77	1,34	1,16
55	-10	408	264	1,85	1,54	1,33
55	-5	515	293	1,94	1,76	1,52
55	0	637	321	2,04	1,98	1,71
55	5	775	350	2,15	2,21	1,91
55	7,2	841	363	2,20	2,31	2,00
55	10	929	380	2,27	2,44	2,11

60	-25	168	185	1,65	0,91	0,79
60	-20	220	214	1,72	1,03	0,89
60	-15	288	244	1,80	1,18	1,02
60	-10	372	274	1,88	1,36	1,17
60	-5	471	305	1,98	1,54	1,33
60	0	586	336	2,09	1,74	1,51
60	5	716	367	2,22	1,95	1,68
60	7,2	779	381	2,27	2,04	1,76
60	10	862	399	2,35	2,16	1,87

65	-25	154	187	1,65	0,82	0,71
65	-20	199	219	1,73	0,91	0,78
65	-15	259	252	1,82	1,03	0,89
65	-10	335	284	1,92	1,18	1,02
65	-5	427	317	2,03	1,35	1,16
65	0	535	351	2,15	1,52	1,32
65	5	658	385	2,29	1,71	1,48
65	7,2	717	400	2,35	1,79	1,55
65	10	796	419	2,44	1,90	1,64

EN12900

X	Cooling Capacity (W)	Consumption (W)	Current (A)	Mass Flow (kg/h)
1	1.205,4268463118	164,0347731308	1,4521172438	20,052655280483
2	42,5019274354	0,5709665069	-0,0003235438	0,79866301523087
3	-10,6147905627	3,0145076624	0,0112778045	-0,066494539840542
4	0,3073260554	0,0097689175	0,0002010894	0,0089191959543962
5	-0,3098564721	0,0986562718	0,0004038388	-0,0018398405023339

Equation	$x_1 + x_2Te + x_3Tc + x_4Te^2 + x_5TeTc$
----------	---

COMPRESSOR DIMENSIONS

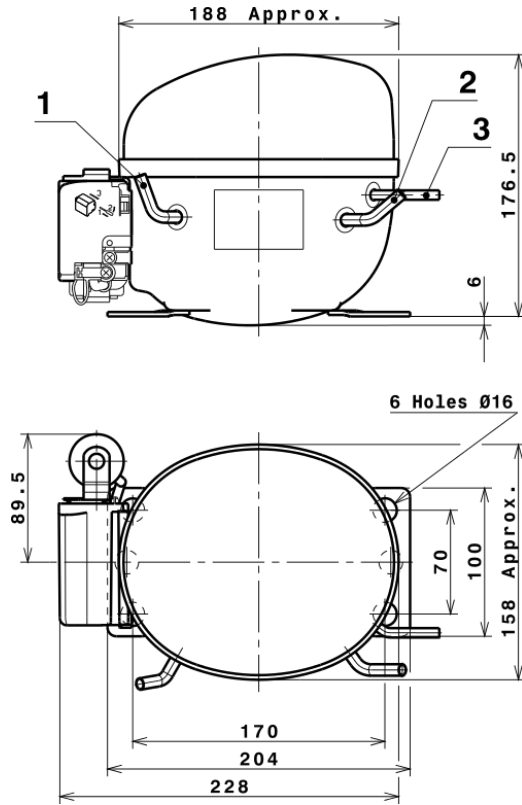

DESIGNATION INTERNAL DIAM.

DESIGNATION	INTERNAL DIAM.
1 Service	6,2 mm
2 Suction	6,2 mm
3 Discharge	4,9 mm

WIRING DIAGRAMS AND ELECTRICAL ASSEMBLY

CSIR CONNECTION (U range)

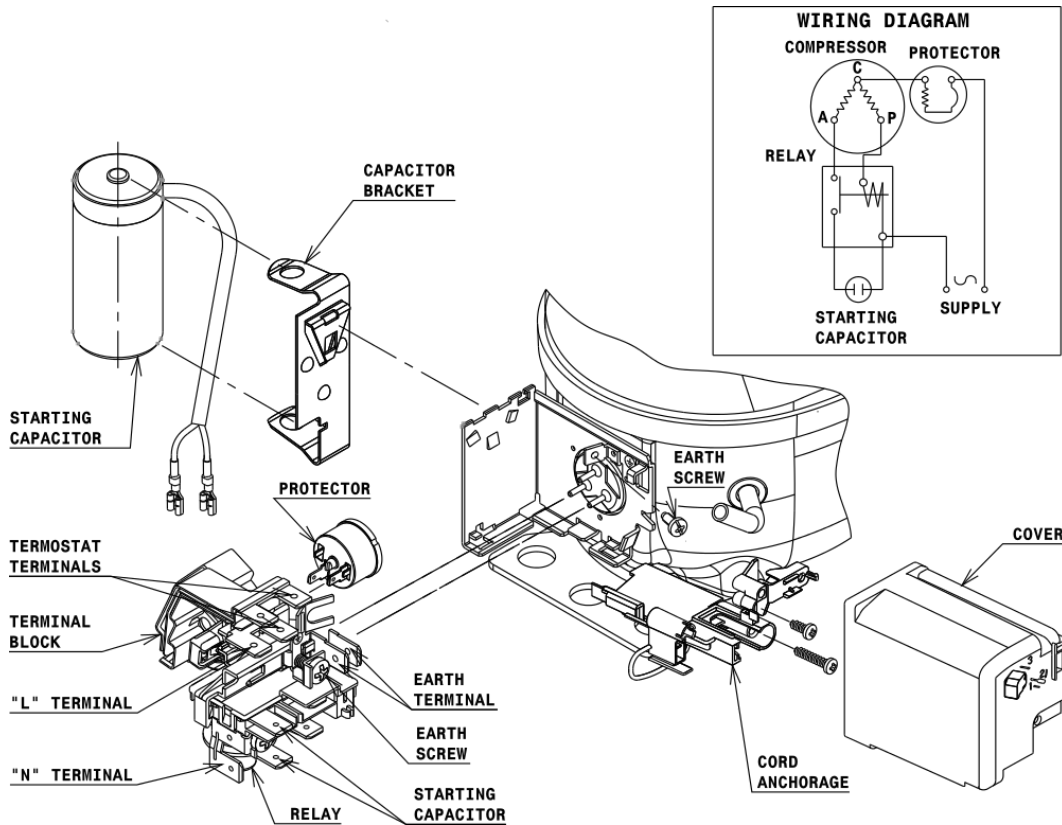

FIXINGS

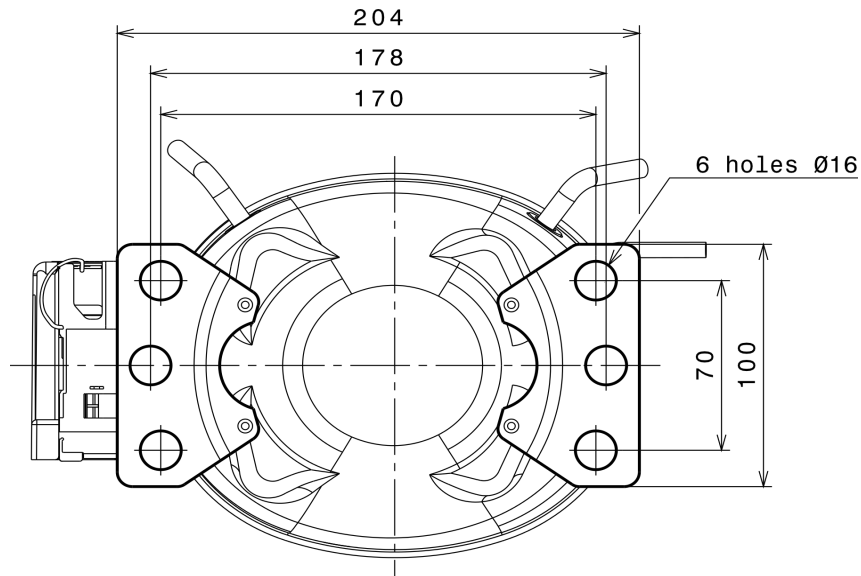

SILENT BLOCKS (MOUNTING ACCESSORIES)

STANDARD

Ø16 holes (170x70 net)

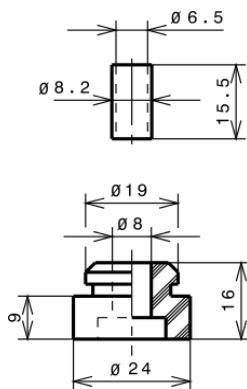

SNAP-ON

Ø16 holes (170x70 net)

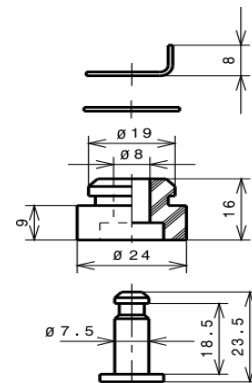

SOA

SOA R134a HMBP

