

Condensing Unit Technical Data Sheet

Model CMS34T3_N
Voltage 400/440V 50/60Hz ~3
Refrigerant R404A

APPLICATION

Application High-Medium Back Pressure
 Refrigerant R404A
 Evaporating Temp. -25,0 °C to 10,0 °C
 Expansion Capillar/Valve
 Comp. Cooling Fan cooled
 Max. ambient temp. 43,0 °C

COMPRESSOR

Displacement 34,42 cm³
 Diameter 42,86 mm
 Stroke 23,85 mm
 Oil type ISO VG 46 ESTER
 Oil charge 887 cm³

MOTOR

Nominal Power 1 5/8 hp
 Voltage/Frequency 400V 50Hz
 Voltage range 340-440 V
 Type 3PHASE
 Phase number 3 PH
 Locked Rotor Amps (LRA) 20,00 A
 Max. Cont. Current (MCC) 6,40 A
 Main W. resist. at 25°C 7,40 Ω
 Start W. resist. at 25°C 10,10 Ω

NOMINAL PERFORMANCE

Cooling Capacity	4.519 W
COP	1,81 W/W
EER	1,56 kCal/Wh
Input Power	2.492 W
Current	4,02 A

ASHRAE

TEST CYCLE CONDITIONS

	HMBP
Evaporating temp. (T _e)	7,2 °C
Condensing temp. (T _c)	55,0 °C
Liquid temp. (T _{liq.})	46,0 °C
Ambient temp. (T _{amb.})	35,0 °C
Suction temp. (T _{suction})	35,0 °C
Voltage/Frequency	400 V 50 Hz

CONDENSER AND FAN DATA

Condenser type	CU-AL
Condenser model	16T 5R
Fan blade (Ø mm / °)	350 / 23
Fan motor	130W 230V 50/60Hz

WIRING DIAGRAM

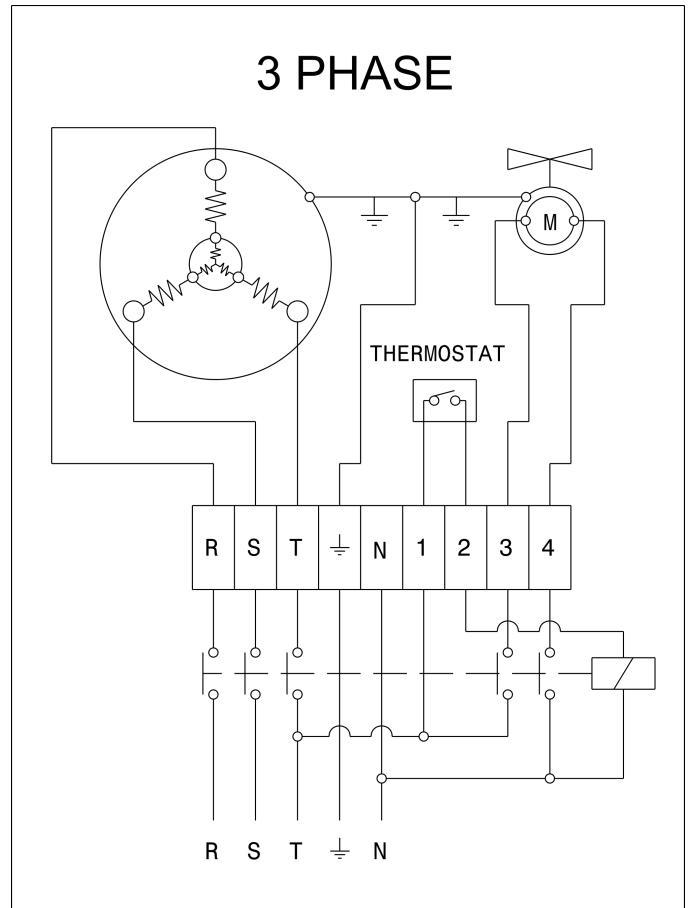

REFRIGERATION CAPACITY (W) Evaporating Temperature (°C)

Model	Motor	-25	-15	-5	5	7.2			10
						W	Winp	A	
CMS34T3_N	3PHASE	1527	2368	3289	4288	4519	2492	4.02	4818

ASHRAE HMBP: Condensing temperature: 55°C, Liquid temperature: 46°C, Suction temperature: 35°C, Ambient temperature: 35°C

Condensing Unit Technical Data Sheet

VERSIONS

VERSION 1	VERSION 2	VERSION 3	VERSION 3P	VERSION 4
Tube	Service valve	Service valve and receiver	Service valve, receiver, pressure switch	Schrader valve on the service port
Suction tube internal diam.: 12,7 mm Discharge tube internal diam.: 8,0 mm Net Weight: 41,5 Kg	Suction valve: 5/8" Discharge valve: 3/8" Net Weight: 42,5 Kg	Receiver vol.: 2,4 l Suction valve: 5/8" Discharge valve: 3/8" Net Weight: 44,0 Kg	Receiver vol.: 2,4 l Suction valve: 5/8" Discharge valve: 3/8" Net Weight: 45,1 Kg	Suction tube internal diam.: 12,7 mm Discharge tube internal diam.: 8,0 mm Net Weight: 41,5 Kg

DIMENSIONS (Version 3 drawing)

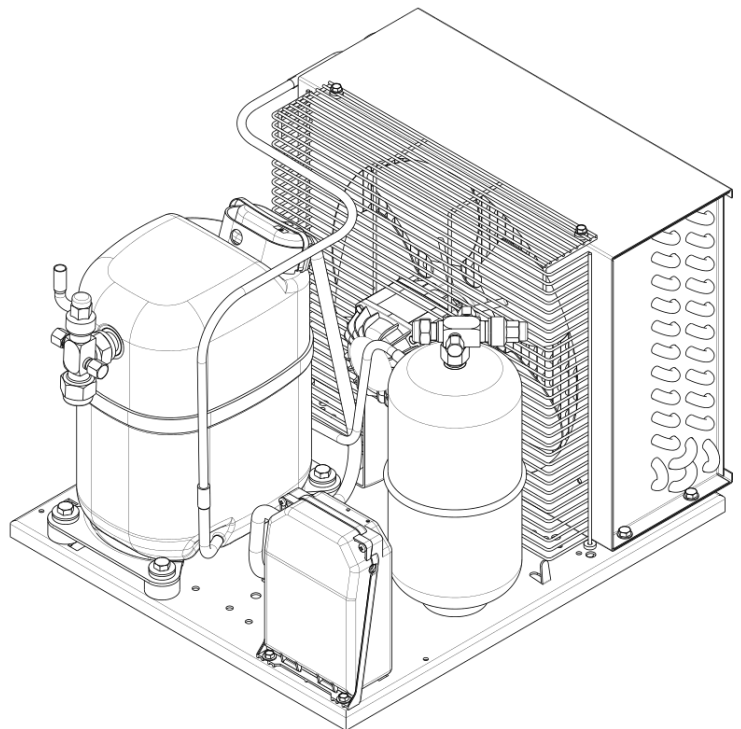
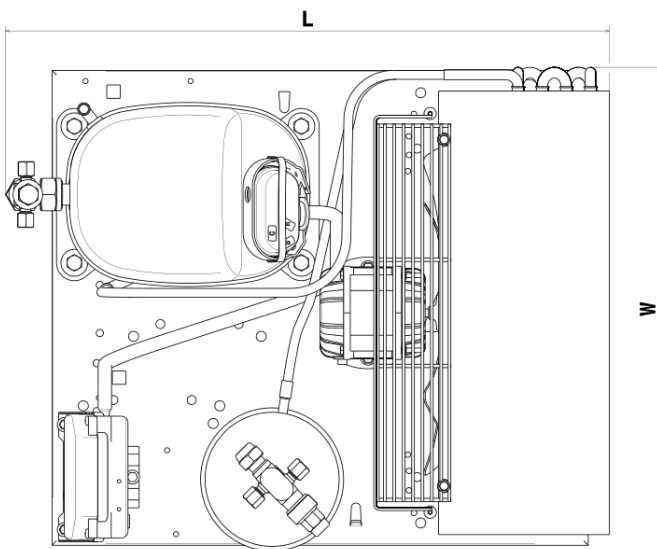
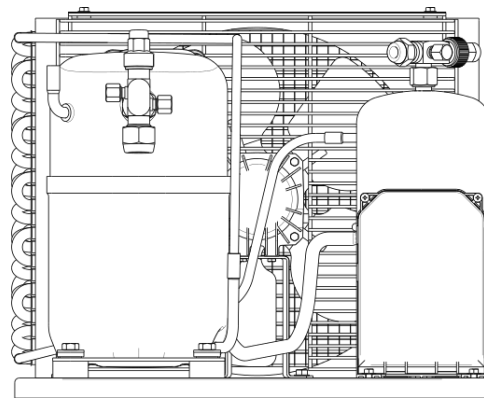
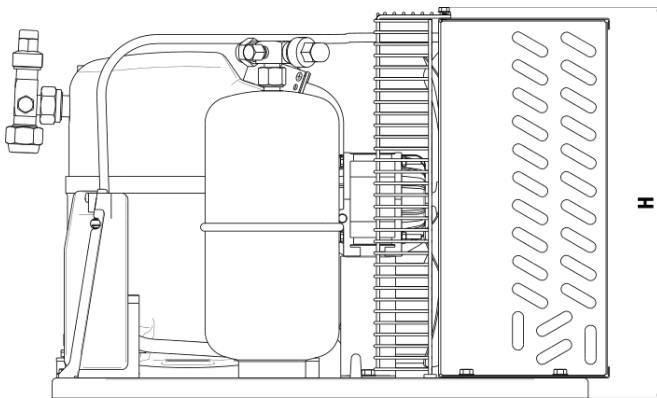

VERSION 1-4 (WxLxH) (mm)	VERSION 2 (WxLxH) (mm)	VERSION 3 (WxLxH) (mm)	VERSION 3P (WxLxH) (mm)
460x505x440	460x520x440	460x520x440	460x520x440