

Condensing Unit Technical Data Sheet

Model CML60FB_N
Voltage 220-240V 50Hz ~1
Refrigerant R404A

APPLICATION

Application Low Back Pressure
 Refrigerant R404A
 Evaporating Temp. -40,0 °C to -10,0 °C
 Expansion Capillar/Valve
 Comp. Cooling Fan cooled
 Max. ambient temp. 43,0 °C

COMPRESSOR

Displacement 5,98 cm³
 Diameter 20,88 mm
 Stroke 17,47 mm
 Oil type ISO VG 32 ESTER
 Oil charge 265 cm³

MOTOR

Nominal Power 1/5 hp
 Voltage/Frequency 220-240V 50Hz
 Voltage range 198-255 V
 Type CSIR
 Phase number 1 PH
 Locked Rotor Amps (LRA) 9,00 A
 Max. Cont. Current (MCC) 1,90 A
 Main W. resist. at 25°C 12,30 Ω
 Start W. resist. at 25°C 37,80 Ω

NOMINAL PERFORMANCE

Cooling Capacity	277 W
COP	1,03 W/W
EER	0,89 kCal/Wh
Input Power	268 W
Current	0,99 A

ASHRAE

TEST CYCLE CONDITIONS

	LBP
Evaporating temp. (T _e)	-23,3 °C
Condensing temp. (T _c)	55,0 °C
Liquid temp. (T _{liq.})	32,0 °C
Ambient temp. (T _{amb.})	32,0 °C
Suction temp. (T _{suction})	32,0 °C
Voltage/Frequency	220 V 50 Hz

CONDENSER AND FAN DATA

Condenser type	CU-AL
Condenser model	7T 2R
Fan blade (Ø mm / °)	172 / 28
Fan motor	5W 230V 50/60Hz

WIRING DIAGRAM

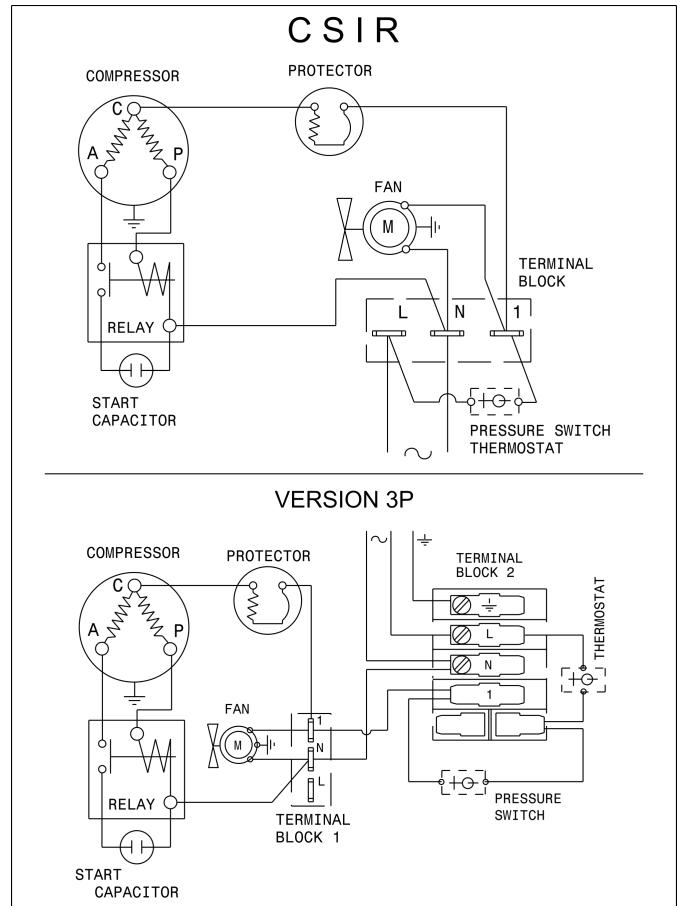

REFRIGERATION CAPACITY (W) Evaporating Temperature (°C)

Model	Motor	-40	-35	-30	-25	-23.3			-10
						W	Winp	A	
CML60FB_N	CSIR	122	161	206	258	277	268	0.99	453

ASHRAE LBP: Condensing temperature: 55°C, Liquid temperature: 32°C, Suction temperature: 32°C, Ambient temperature: 32°C

Condensing Unit Technical Data Sheet

VERSIONS

VERSION 1	VERSION 2	VERSION 3	VERSION 3P	VERSION 4
Tube	Service valve	Service valve and receiver	Service valve, receiver, pressure switch	Schrader valve on the service port
Suction tube internal diam.: 6,5 mm Discharge tube internal diam.: 4,9 mm Net Weight: 15,7 Kg	Suction valve: 3/8" Discharge valve: 1/4" Net Weight: 16,2 Kg	Receiver vol.: 0,9 l Suction valve: 3/8" Discharge valve: 1/4" Net Weight: 16,5 Kg	Receiver vol.: 0,9 l Suction valve: 3/8" Discharge valve: 1/4" Net Weight: 17,6 Kg	Suction tube internal diam.: 6,5 mm Discharge tube internal diam.: 4,9 mm Net Weight: 15,7 Kg

DIMENSIONS (Version 3 drawing)

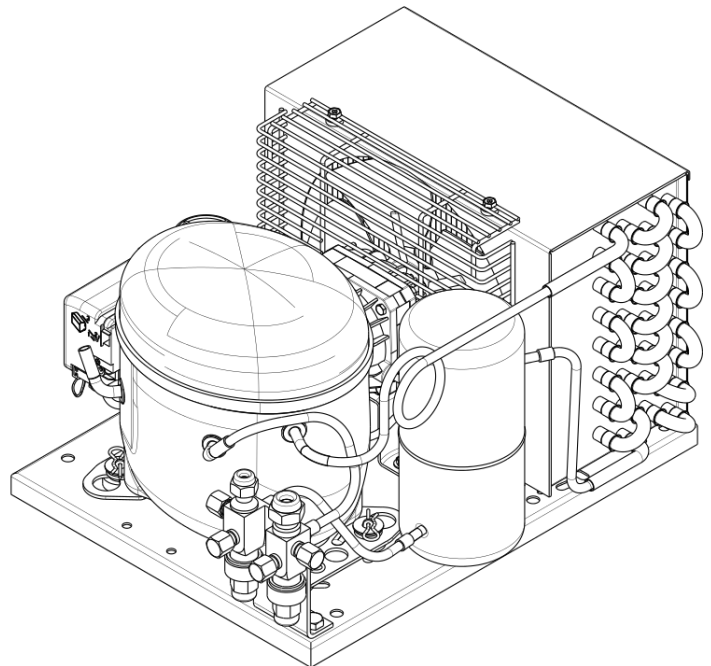
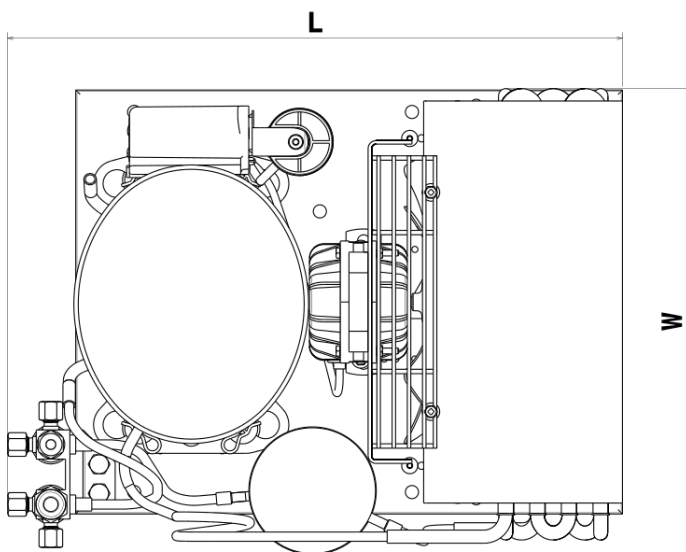
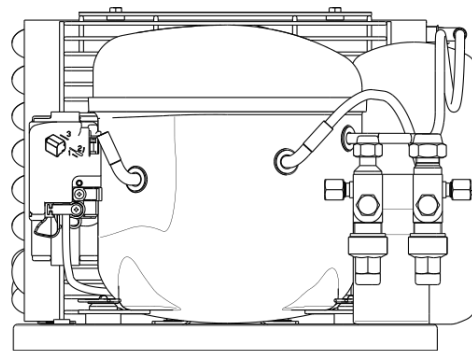
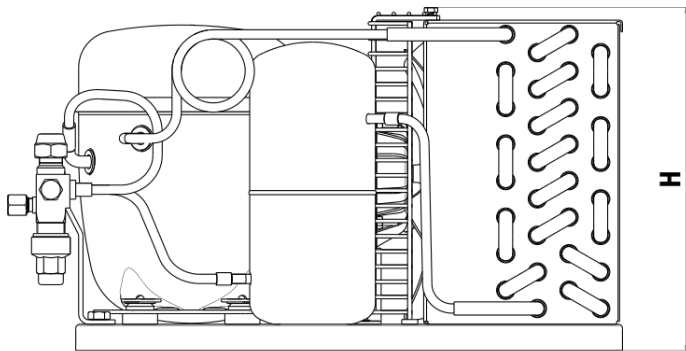

VERSION 1-4 (WxLxH) (mm)	VERSION 2 (WxLxH) (mm)	VERSION 3 (WxLxH) (mm)	VERSION 3P (WxLxH) (mm)
305x385x215	315x425x215	330x425x215	330x435x245