

# Technical Data Sheet

Compressor model **B52CL**  
 Voltage **220-240V 50Hz ~1**  
 Refrigerant **R600a**

## APPLICATION

Application Low Back Pressure  
 Refrigerant R600a  
 Evaporating Temp. -35,0 °C to -15,0 °C  
 Expansion Capillar  
 Comp. Cooling Static  
 Max. ambient temp. 43,0 °C

## COMPRESSOR

Displacement 5,20 cm<sup>3</sup>  
 Diameter 21,00 mm  
 Stroke 15,20 mm  
 Net Weight 5,20 Kg  
 Oil type ISO VG 10 MINER  
 Oil charge 130 cm<sup>3</sup>

## MOTOR

Nominal Power 1/10 hp  
 Voltage/Frequency 220-240V 50Hz  
 Voltage range 187-255 V  
 Type RSIR  
 Phase number 1 PH  
 Locked Rotor Amps (LRA) 2,51 A  
 Max. Cont. Current (MCC) 0,63 A  
 Main W. resist. at 25°C 47,95 Ω  
 Start W. resist. at 25°C 16,30 Ω

## NOMINAL PERFORMANCE

	ASHRAE	CECOMAF
Cooling Capacity	67 kCal/h	58 W
COP	1,42 W/W	1,11 W/W
EER	1,22 kCal/Wh	0,96 kCal/Wh
Input Power	55 W	53 W
Current	0,44 A	0,43 A

## APPROVALS

## TEST CYCLE CONDITIONS

	ASHRAE LBP (B)	CECOMAF LBP (A)
Evaporating temp. (T <sub>e</sub> )	-23,3 °C	-25,0 °C
Condensing temp. (T <sub>c</sub> )	55,0 °C	55,0 °C
Liquid temp. (T <sub>liq.</sub> )	32,0 °C	55,0 °C
Ambient temp. (T <sub>amb.</sub> )	32,0 °C	32,0 °C
Suction temp. (T <sub>suction</sub> )	32,0 °C	32,0 °C
Voltage/Frequency	220 V 50 Hz	220 V 50 Hz

## ELECTRICAL COMPONENTS

Relay	Option 1	Option 2		
Reference	JPQII-15 (019)	QP2-15 (019)		
Voltage	V	V		
Resistance	Ω	Ω		
Protector	Option 1	Option 2	Option 3	
Reference	BT27-125 (044)	BT27-125A61D3 (044)	DRB135P61A2 (044)	
Current	2,70 A		2,70 A	
Time check	7-16 seg		7-16 seg	
Disc temp. (Open/Close)	125,00 / 61,00 °C		125,00 / 61,00 °C	

This product is approved for R290 and R600a regarding explosion safety according to standard EN 60335-1 and EN 60335-2-34

# Technical Data Sheet

## ASHRAE

Tc °C	Te °C	Cooling Capacity kCal/h	Consumption W	Current A	COP W/W	EER kCal/Wh
40	-35	42	40	0,36	1,22	1,05
40	-30	54	45	0,39	1,39	1,20
40	-25	70	51	0,42	1,60	1,38
40	-23,3	77	53	0,43	1,68	1,45
40	-20	91	57	0,45	1,83	1,58
40	-15	115	64	0,49	2,07	1,78
40	-10	143	72	0,54	2,31	1,99

45	-35	40	40	0,36	1,15	0,99
45	-30	51	45	0,39	1,32	1,13
45	-25	67	52	0,42	1,52	1,30
45	-23,3	74	54	0,43	1,59	1,37
45	-20	87	58	0,46	1,74	1,50
45	-15	111	65	0,50	1,97	1,69
45	-10	139	73	0,54	2,20	1,89

50	-35	37	40	0,36	1,09	0,93
50	-30	49	46	0,39	1,24	1,07
50	-25	64	52	0,42	1,43	1,23
50	-23,3	70	54	0,44	1,50	1,29
50	-20	84	59	0,46	1,65	1,42
50	-15	107	67	0,50	1,87	1,61
50	-10	134	75	0,55	2,09	1,80

55	-35	35	40	0,36	1,02	0,88
55	-30	46	46	0,39	1,16	1,00
55	-25	61	53	0,43	1,35	1,16
55	-23,3	67	55	0,44	1,42	1,22
55	-20	80	60	0,47	1,56	1,34
55	-15	103	68	0,51	1,77	1,52
55	-10	130	76	0,56	1,99	1,71

60	-35	33	40	0,36	0,95	0,82
60	-30	43	46	0,39	1,09	0,93
60	-25	58	53	0,43	1,27	1,09
60	-23,3	64	56	0,44	1,33	1,15
60	-20	76	61	0,47	1,47	1,26
60	-15	99	69	0,52	1,68	1,44
60	-10	126	77	0,57	1,89	1,63

## CECOMAF

Tc °C	Te °C	Cooling Capacity W	Consumption W	Current A	COP W/W	EER kCal/Wh
40	-35	46	40	0,36	1,15	0,99
40	-30	60	45	0,39	1,34	1,15
40	-25	79	51	0,42	1,54	1,33
40	-23,3	86	53	0,43	1,61	1,39
40	-20	101	57	0,45	1,75	1,52
40	-15	127	64	0,49	1,97	1,70
40	-10	156	72	0,54	2,17	1,88

45	-35	42	40	0,36	1,05	0,90
45	-30	55	45	0,39	1,21	1,04
45	-25	72	52	0,42	1,39	1,20
45	-23,3	79	54	0,43	1,46	1,26
45	-20	93	58	0,46	1,59	1,38
45	-15	117	65	0,50	1,79	1,55
45	-10	146	73	0,54	1,99	1,72

50	-35	38	40	0,36	0,94	0,81
50	-30	50	46	0,39	1,08	0,94
50	-25	65	52	0,42	1,25	1,08
50	-23,3	71	54	0,44	1,31	1,13
50	-20	85	59	0,46	1,43	1,24
50	-15	108	67	0,50	1,62	1,40
50	-10	135	75	0,55	1,81	1,56

55	-35	34	40	0,36	0,84	0,72
55	-30	44	46	0,39	0,96	0,83
55	-25	58	53	0,43	1,11	0,96
55	-23,3	64	55	0,44	1,17	1,01
55	-20	77	60	0,47	1,28	1,11
55	-15	99	68	0,51	1,46	1,26
55	-10	124	76	0,56	1,64	1,41

60	-35	29	40	0,36	0,74	0,64
60	-30	39	46	0,39	0,84	0,72
60	-25	52	53	0,43	0,97	0,84
60	-23,3	57	56	0,44	1,03	0,89
60	-20	69	61	0,47	1,13	0,98
60	-15	89	69	0,52	1,30	1,12
60	-10	114	77	0,57	1,47	1,27

## EN12900

X	Cooling Capacity (W)	Consumption (W)	Current (A)	Mass Flow (kg/h)
1	329,2915365505	75,7544339367	0,5598425773	3,3223355629347
2	9,7754194128	1,4269167422	0,0087683004	0,10989454573384
3	-2,6881110223	0,3817274464	0,0022634122	-0,013491269511352
4	0,0740422602	0,0122709969	0,0000909588	0,0010708874995316
5	-0,0532040054	0,0109064985	0,0000646689	-0,00021230799720862

Equation	$x_1 + x_2Te + x_3Tc + x_4Te^2 + x_5TeTc$
----------	---

# Technical Data Sheet

## COMPRESSOR DIMENSIONS

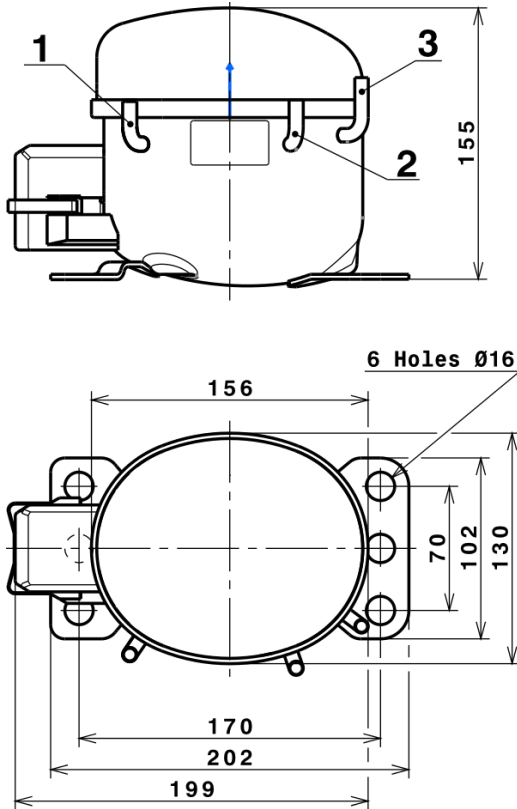

DESIGNATION	INTERNAL DIAM.
1 Suction	6,1 mm
2 Service	6,1 mm
3 Discharge	5,1 mm

## WIRING DIAGRAMS AND ELECTRICAL ASSEMBLY

### RSIR CONNECTION (PTC) (B, Small L ranges)

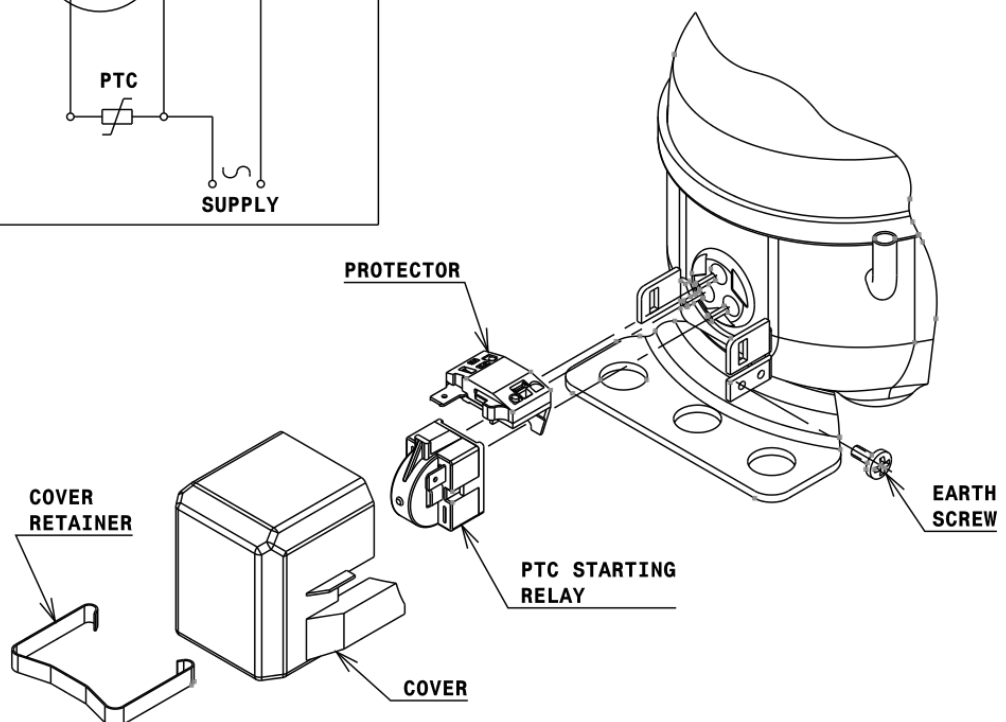
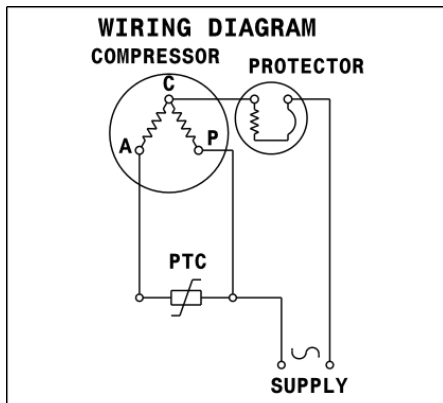

# Technical Data Sheet

## FIXINGS

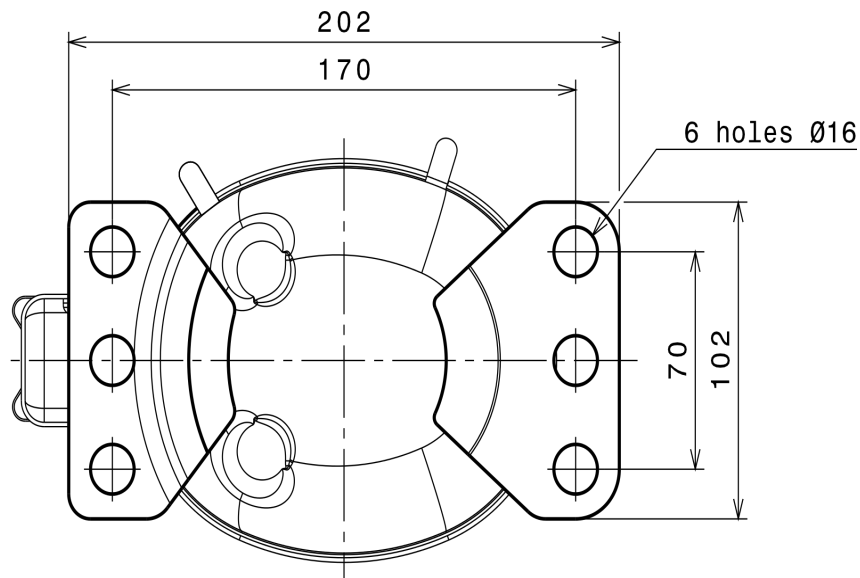

## SILENT BLOCKS (MOUNTING ACCESSORIES)

### STANDARD

Ø16 holes (170x70 net)

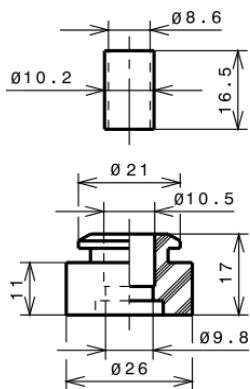

### SOA

SOA R600a LBP

